

Vehicle Type	Ford Transit, Mercedes Sprinter, Volkswagen, KIA Bongo, Opel, Fiat Boxer etc.
Gearbox Type	Horizontal Split Shaft Power Take-Off

Product Code	UARA.210.1
Revision No-Date	02 / 03.10.2018

Product Views

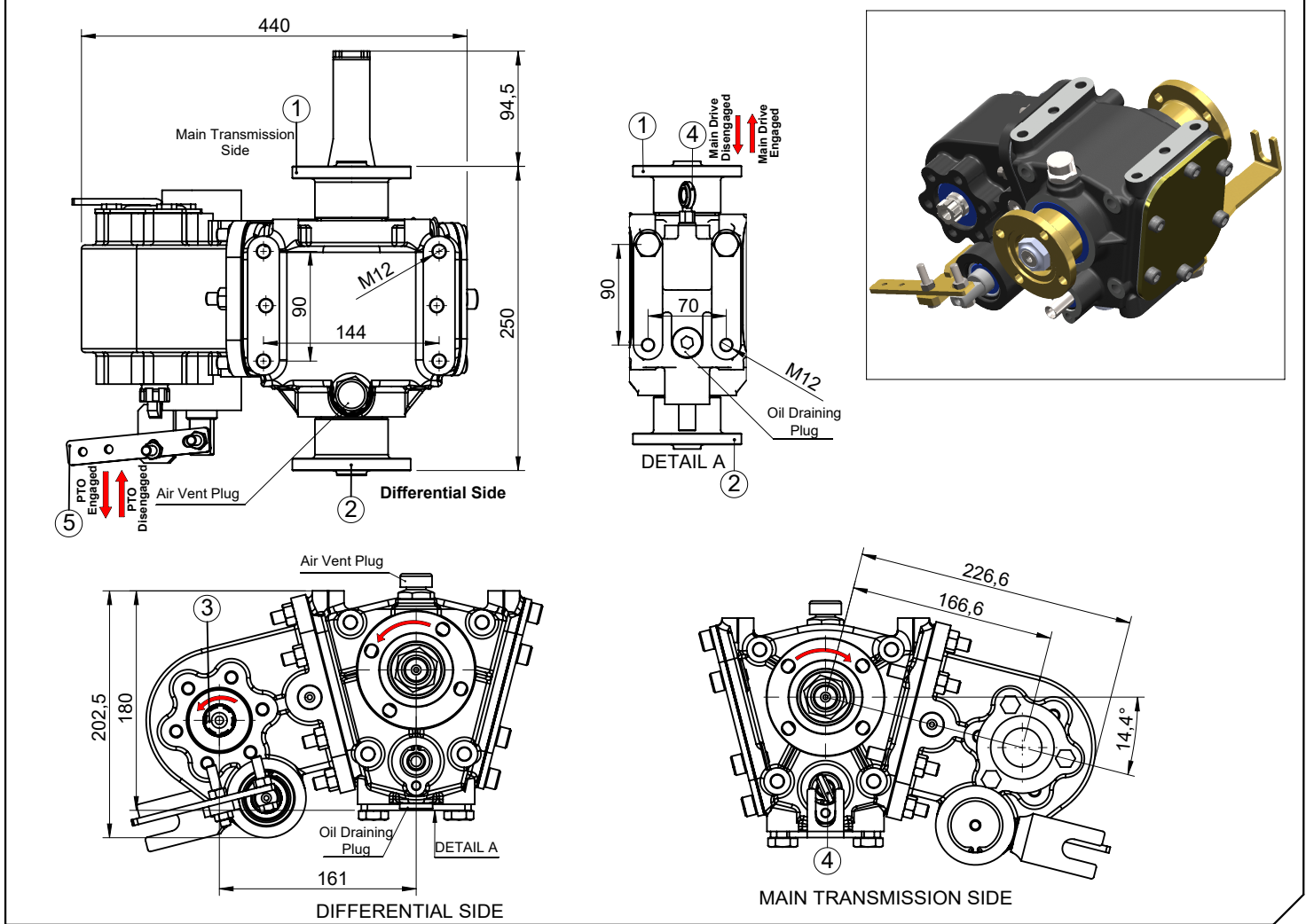

Component Details	
<p>1 : Main Input / ISO 7647 - ISO 7646 Standard Flange 2 : Main Output / ISO 7647 - ISO 7646 Standard Flange 3 : Side Output / UNI 3 Bolts (21x25x6 - DIN 5463) or ISO 7647 - ISO 7646 Standard Flange</p>	<p>4 : Mechanic Lever for Engage/Disengage Main Drive 5 : Mechanic Lever for Engage/Disengage Side Output</p>

Technical Details					
Outputs	Max. Values	Max. RPM	Input/Output	Mounting Type	Control Type
1 & 2	210 kgm	2500- 3000 rpm	1/1	Split Shaft	Pneumatic or Mechanic
3	25 Kw	1250 - 1500 rpm	1/1.42	Weight	Sense of Rotation
				25 kg	Opposite of Input



Ofis / Office
Tel. +90 312 354 05 39
Fax +90 312 354 34 59
7. Sokak No: 9
Ostim / ANKARA
e-mail: info@kozmaksan.com.tr

Fabrika / Factory
Tel. +90 312 267 39 71
Fax +90 312 267 38 72
AOS. 1. OSB. Erkunt Cad. No: 6
Sincan / ANKARA
Website: www.kozmaksan.com.tr